

CONTENT
ELEMENT TYPES
KERTO-RIPA ROOF ELEMENT
BOX SLAB

SCALE
1:20

DATE

20.12.2013

DRAWING NUMBER

112

**112-01 KERTO-RIPA ROOF ELEMENT
BOX SLAB REI60, LOW-PITCHED ROOF**

20.12.2013

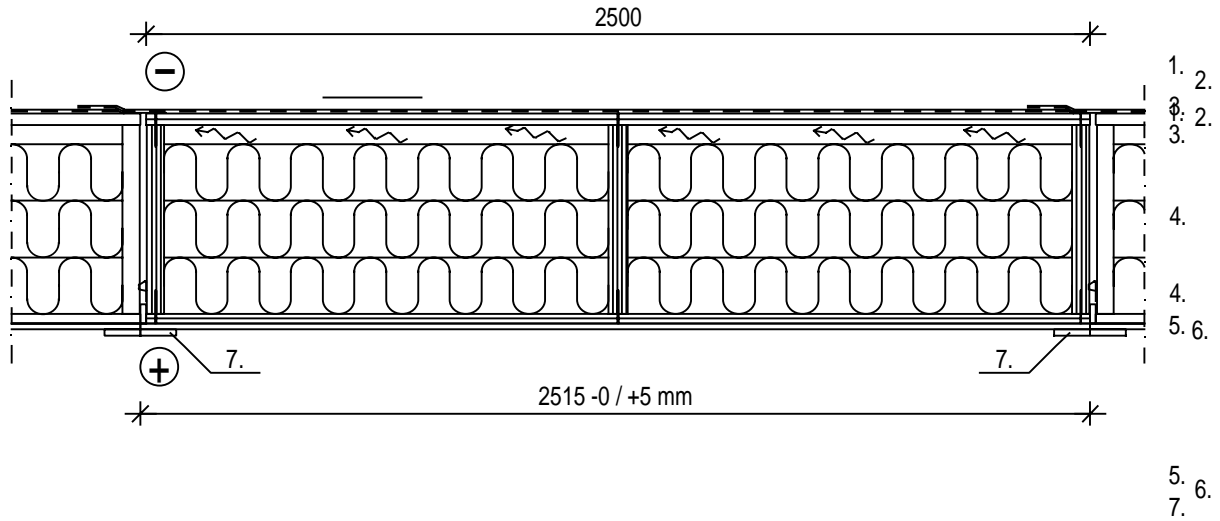

ROOF ELEMENT MANUFACTURING:

1. 1-LAYER PVC ROOF MEMBRANE OR BITUMINOUS UNDERLAY MEMBRANE TL2
2. KERTO-Q TOP SLAB (STRUCTURALLY GLUED)
3. VENTILATING GAP ≥ 20 mm
4. KERTO-S RIBS $c/c \leq 1250$ mm + THERMAL INSULATION A2-s1,d0, CLASSIFICATION OF TOP SURFACE B-s1,d0
5. KERTO-Q BOTTOM SLAB (STRUCTURALLY GLUED), VAPOUR BARRIER
6. GYPSUM PLASTERBOARD (TYPE A OR F)
7. TIMBER 18x95 mm, ON BOARDS LONGITUDINAL SIDE, IF THE CLASSIFICATION RATE OF THE BOARD SHEETING AND INTERIOR SURFACE IS max. D-s2,d2

**112-02 KERTO-RIPA ROOF ELEMENT
BOX SLAB REI30, LOW-PITCHED ROOF**

20.12.2013

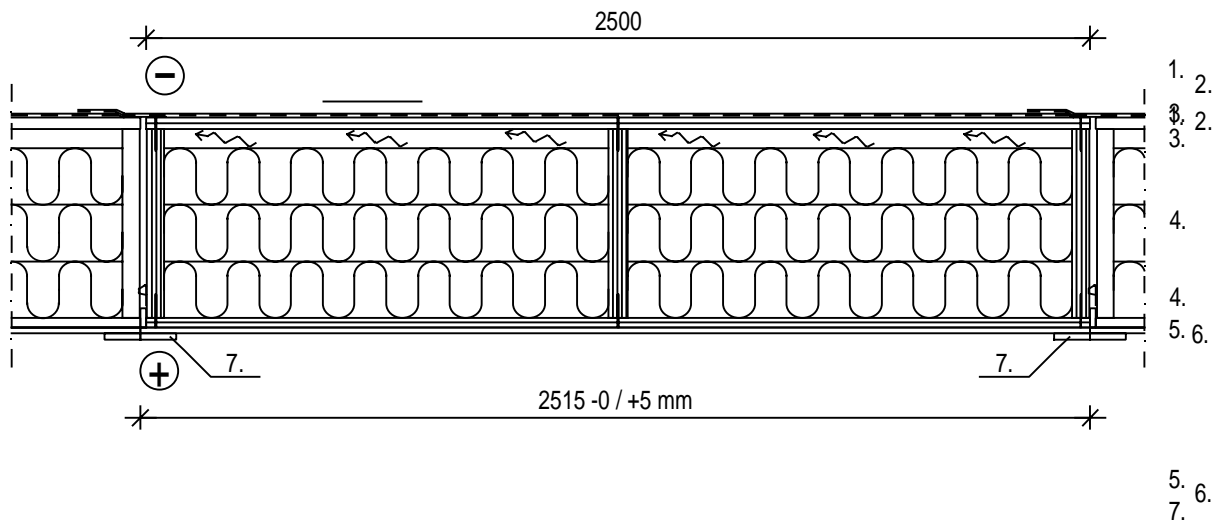

ROOF ELEMENT MANUFACTURING:

1. 1-LAYER PVC ROOF MEMBRANE OR BITUMINOUS UNDERLAY MEMBRANE TL2
2. KERTO-Q TOP SLAB (STRUCTURALLY GLUED)
3. VENTILATING GAP ≥ 20 mm
4. KERTO-S RIBS $c/c \leq 1250$ mm + THERMAL INSULATION A2-s1,d0, CLASSIFICATION OF TOP SURFACE B-s1,d0
5. KERTO-Q BOTTOM SLAB (STRUCTURALLY GLUED), VAPOUR BARRIER
6. GYPSUM PLASTERBOARD (TYPE A OR F)
7. TIMBER 18x95 mm, ON BOARDS LONGITUDINAL SIDE, IF THE CLASSIFICATION RATE OF THE BOARD SHEETING AND INTERIOR SURFACE IS max. D-s2,d2

**112-03 KERTO-RIPA ROOF ELEMENT
BOX SLAB REI60, HIGH-PITCHED ROOF**

20.12.2013

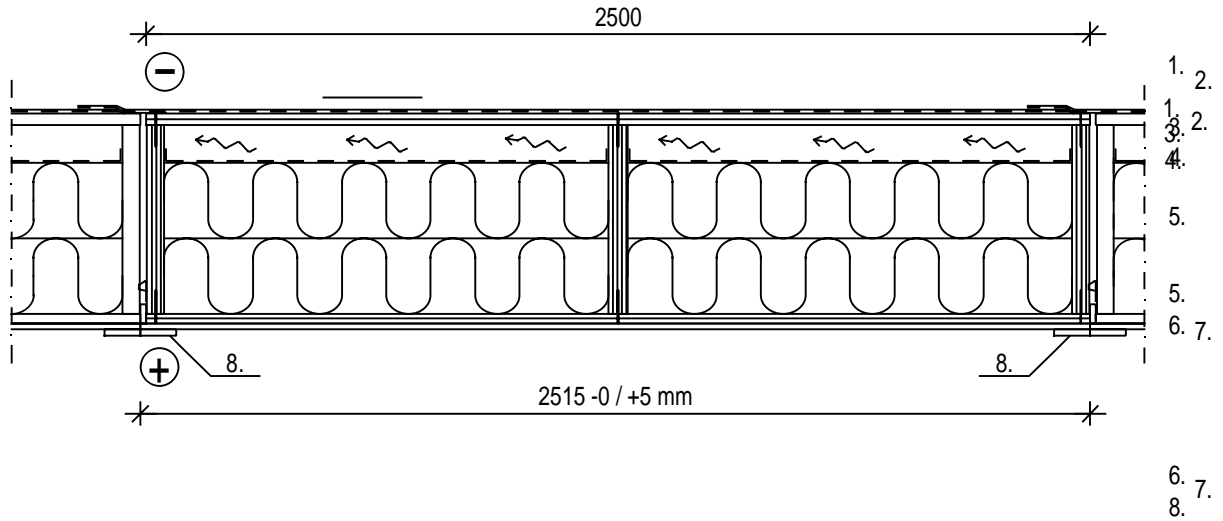

ROOF ELEMENT MANUFACTURING:

1. 1-LAYER PVC ROOF MEMBRANE OR BITUMINOUS UNDERLAY MEMBRANE TL2
2. KERTO-Q TOP SLAB (STRUCTURALLY GLUED)
3. VENTILATING GAP ≥ 100 mm
4. WIND BARRIER, CLASSIFICATION B-s1,d0
5. KERTO-S RIBS $c/c \leq 1250$ mm + THERMAL INSULATION A2-s1,d0, CLASSIFICATION OF TOP SURFACE B-s1,d0
6. KERTO-Q BOTTOM SLAB (STRUCTURALLY GLUED), VAPOUR BARRIER
7. GYPSUM PLASTERBOARD (TYPE A OR F)
8. TIMBER 18x95 mm, ON BOARDS LONGITUDINAL SIDE, IF THE CLASSIFICATION RATE OF THE BOARD SHEETING AND INTERIOR SURFACE IS max. D-s2,d2

**112-04 KERTO-RIPA ROOF ELEMENT
BOX SLAB REI30, HIGH-PITCHED ROOF**

20.12.2013

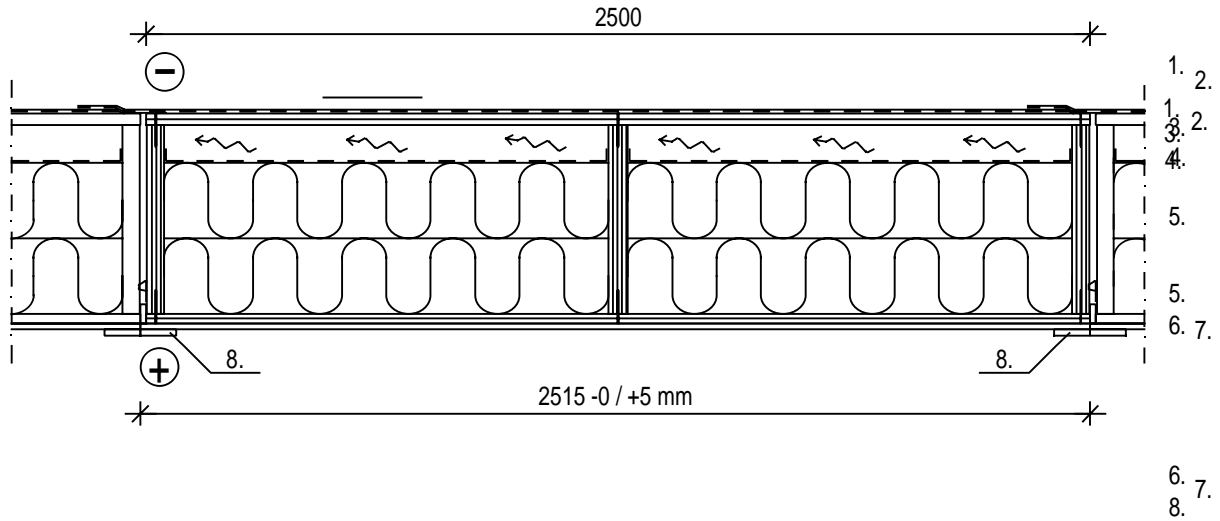

ROOF ELEMENT MANUFACTURING:

1. 1-LAYER PVC ROOF MEMBRANE OR BITUMINOUS UNDERLAY MEMBRANE TL2
2. KERTO-Q TOP SLAB (STRUCTURALLY GLUED)
3. VENTILATING GAP ≥ 100 mm
4. WIND BARRIER, CLASSIFICATION B-s1,d0
5. KERTO-S RIBS $c/c \leq 1250$ mm + THERMAL INSULATION A2-s1,d0, CLASSIFICATION OF TOP SURFACE B-s1,d0
6. KERTO-Q BOTTOM SLAB (STRUCTURALLY GLUED), VAPOUR BARRIER
7. GYPSUM PLASTERBOARD (TYPE A OR F)
8. TIMBER 18x95 mm, ON BOARDS LONGITUDINAL SIDE, IF THE CLASSIFICATION RATE OF THE BOARD SHEETING AND INTERIOR SURFACE IS max. D-s2,d2